

# 積層チップNTCサーミスタ MULTILAYER CHIP NTC THERMISTORS



OPERATING TEMP.	-55~+125°C
-----------------	------------

\* 1005TYPEを除く  
\* Except for 1005TYPE

## 特長 FEATURES

- ・125°C保証
- ・B定数が大きく温度検知能力が優れている
- ・表裏の区別がなくバルク、テーピングでの自動装着が可能
- ・寸法はEIAJ規格に準拠
- ・内部電極構造を採用することにより、信頼性向上を実現しています
- ・Guaranteed up to 125°C.
- ・Large B constant for higher temperature sensing capability.
- ・Ideal for automatic mounting in bulk or from tapes because of front-rear symmetry.
- ・Available in a standard EIA compatible case size.
- ・Improved reliability due to use of internal electrodes.

## 用途 APPLICATIONS

- ・通信機用  
自動車電話、携帯電話、コードレス電話ほか
- ・OA機器用  
プリンタ、ファクシミリ、ワードプロセッサほか
- ・民生機器用  
ビデオ、カラーテレビ、液晶テレビ、CDプレーヤほか
- ・バッテリー保護回路用
- ・Telecommunications equipment : mobile telephones, cellular telephones, cordless telephones, etc.
- ・Office automation : printers, facsimiles, word processors, etc.
- ・Consumer electronics : VCRs, color television sets, LCD television sets, CD players, etc.
- ・Battery protection circuit

## 形名表記法 ORDERING CODE

<b>1</b> 形式 TB   NTCサーミスタ	<b>3</b> 寸法 [mm] S0   1.0×0.5 (0402) S1   1.6×0.8 (0603)	<b>5</b> 公称零負荷抵抗 [Ω] 例     102   1000 154   150000	<b>7</b> 公称B定数 [K] 例   記号×10 295   2950 410   4100	<b>9</b> 最低温度 [°C] 5   -55
<b>2</b> 形状 P   メッキ電極品	<b>4</b> 包装 R   紙テーピング S   単品(袋づめ)	<b>6</b> 抵抗許容差 [%] F   ±1 G   ±2 H   ±3 J   ±5 K   ±10	<b>8</b> B定数許容差 [%] F   ±1 H   ±3	<b>10</b> 最高温度 [°C] Q   125
				<b>11</b> 当社管理記号 △   標準品 △ = スペース

T B P S 1 S 1 0 3 K 4 4 0 H 5 Q ○

1 2 3 4 5 6 7 8 9 10 11

<b>1</b> Type TB   NTC THERMISTOR	<b>3</b> Dimension [mm] S0   1.0×0.5 (0402) S1   1.6×0.8 (0603)	<b>5</b> Nominal Zero-Power Resistance [Ω] example     102   1000 154   150000	<b>7</b> Nominal B constant [K] example   Symbol×10 295   2950 410   4100	<b>9</b> Min. temperature [°C] 5   -55
<b>2</b> Shape P   Plated terminal	<b>4</b> Packaging R   Tape&Reel S   Bulk	<b>6</b> Resistance tolerance [%] F   ±1 G   ±2 H   ±3 J   ±5 K   ±10	<b>8</b> B constant tolerance [%] F   ±1 H   ±3	<b>10</b> Max. temperature [°C] Q   125
				<b>11</b> Internal code △   Standard product △ = Blank space

## 外形寸法 EXTERNAL DIMENSIONS

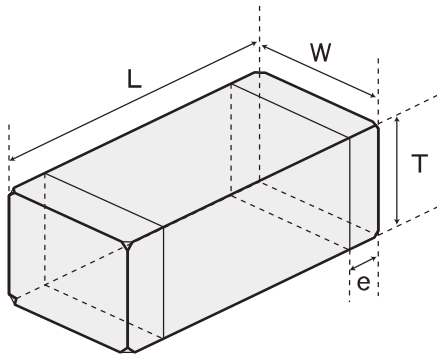

Type	L	W	T	e
1005 (0402)	1.0±0.05 (0.039±0.002)	0.5±0.05 (0.020±0.002)	0.5±0.05 (0.020±0.002)	0.25±0.10 (0.010±0.004)
1608 (0603)	1.6±0.15 (0.063±0.006)	0.8±0.15 (0.031±0.006)	0.8±0.15 (0.031±0.006)	0.35±0.25 (0.014±0.010)

Unit : mm (Inch)

## R-T特性図 R-T CHARACTERISTICS

1005type (0402)

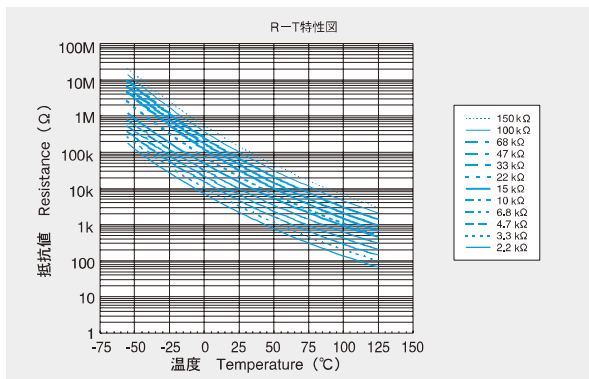

1608type (0603)

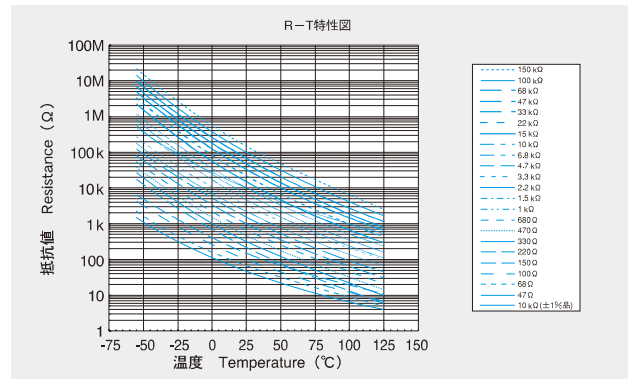

6

THERMISTORS

## 仕様 SPECIFICATIONS

	許容差 (記号) Tolerance (Symbols)
R25	±1% (F), ±2% (G), ±3% (H), ±5% (J), ±10% (K)
B定数 B Constant	±1% (F), ±3% (H)

セレクションガイド  
Selection Guide

P.16

etc

アイテム一覧  
Part Numbers

P.474

特性図  
Electrical Characteristics

P.475

梱包  
Packaging

P.476

信頼性  
Reliability Data

P.478

使用上の注意  
Precautions

※

※営業窓口にご相談ください。Please contact our Sales Department.

1005TYPE

形名 Ordering Code	EHS (Environmental Hazardous Substances)	R25 [kΩ]	B定数 B constant		熱時定数 Thermal time constant	熱放散定数 Dissipation factor	定格電力 Rated Power	備考 Remark
			(K : 25/85°C)	(K : 25/50°C)				
TBPS0○222△410H5Q	RoHS	2.2	4100	4034	≤3 sec	0.5~2.0 mW/°C	35mW	
TBPS0○332△410H5Q	RoHS	3.3	4100	4034				
TBPS0○472△410H5Q	RoHS	4.7	4100	4034				
TBPS0○682△410H5Q	RoHS	6.8	4100	4034				
TBPS0○103△410H5Q	RoHS	10	4100	4034				
TBPS0○153△410H5Q	RoHS	15	4100	4034				
TBPS0○223△440H5Q	RoHS	22	4400	4336				
TBPS0○333△455H5Q	RoHS	33	4550	4483				
TBPS0○473△455H5Q	RoHS	47	4550	4483				
TBPS0○683△455H5Q	RoHS	68	4550	4483				
TBPS0○104△455H5Q	RoHS	100	4550	4483				
TBPS0○154△455H5Q	RoHS	150	4550	4483				

形名の○には包装 (R=テーピング、S=単品)、△には抵抗許容差記号 (J,K) が入ります。  
 ○Please specify the packaging code (R : tape & reel, S : Bulk) and △ the resistance tolerance code (J, K).

1608TYPE

形名 Ordering Code	EHS (Environmental Hazardous Substances)	R25 [kΩ]	B定数 B constant		熱時定数 Thermal time constant	熱放散定数 Dissipation factor	定格電力 Rated Power	備考 Remark
			(K : 25/85°C)	(K : 25/50°C)				
TBPS1○470△295H5Q	RoHS	0.047	2950	2934	≤5 sec	1.0~2.5 mW/°C	63mW	
TBPS1○680△295H5Q	RoHS	0.068	2950	2934				
TBPS1○101△315H5Q	RoHS	0.100	3150	3157				
TBPS1○151△315H5Q	RoHS	0.150	3150	3157				
TBPS1○221△410H5Q	RoHS	0.22	4100	4034				
TBPS1○331△410H5Q	RoHS	0.33	4100	4034				
TBPS1○471△410H5Q	RoHS	0.47	4100	4034				
TBPS1○681△410H5Q	RoHS	0.68	4100	4034				
TBPS1○102△410H5Q	RoHS	1.0	4100	4034				
TBPS1○152△410H5Q	RoHS	1.5	4100	4034				
TBPS1○222△410H5Q	RoHS	2.2	4100	4034				
TBPS1○332△410H5Q	RoHS	3.3	4100	4034				
TBPS1○472△440H5Q	RoHS	4.7	4400	4336				
TBPS1○682△440H5Q	RoHS	6.8	4400	4336				
TBPS1○103△440H5Q	RoHS	10	4400	4336				
TBPS1○153△460H5Q	RoHS	15	4600	4533				
TBPS1○223△460H5Q	RoHS	22	4600	4533				
TBPS1○333△460H5Q	RoHS	33	4600	4533				
TBPS1○473△475H5Q	RoHS	47	4750	4642				
TBPS1○683△475H5Q	RoHS	68	4750	4642				
TBPS1○104△475H5Q	RoHS	100	4750	4642				
TBPS1○154△475H5Q	RoHS	150	4750	4642				
TBPS1○103△344F5Q	RoHS	10	3435	3395				

形名の○には包装 (R=テーピング、S=単品)、△には抵抗値許容差記号 (J, K (TBP S1 ○ 103 △ 344 F 5QはF,GまたはH)) が入ります。  
 ○Please specify the packaging code (R : tape & reel, S : Bulk) and △ the resistance tolerance code (F,G or H for TBP S1 ○ 103 △ 344 F 5Q J, K for other part numbers).

1005type (0402)

高温放置 High Temperature Life Test  
 試験条件 Test Condition 125°C

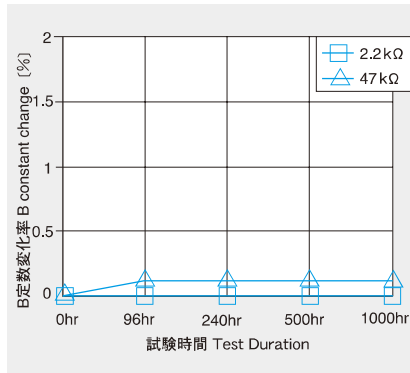
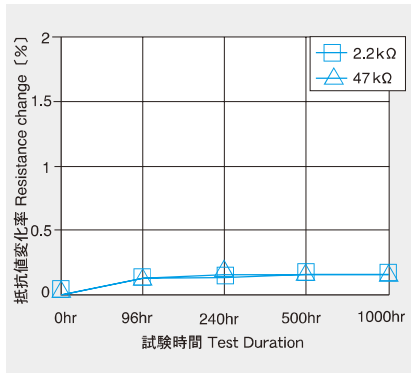

耐湿性 Damp Heat (steady state)

試験条件 Test Condition 85°C95%

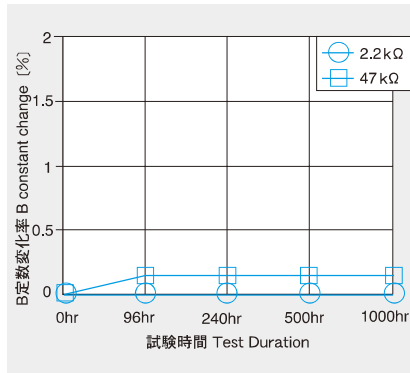
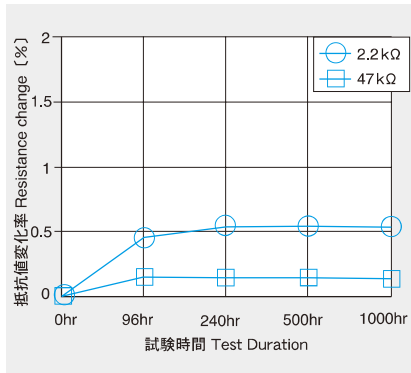

1608type (0603)

高温放置 High Temperature Life Test  
 試験条件 Test Condition 125°C

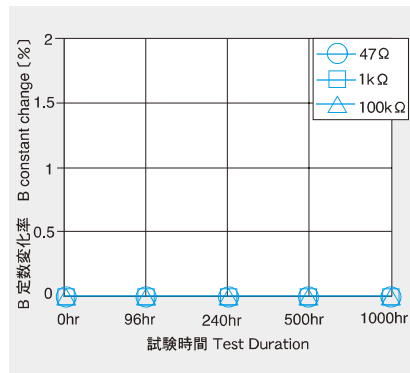
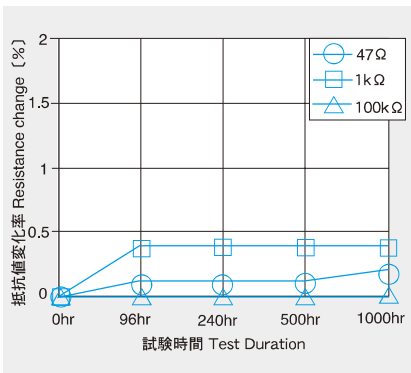

耐湿性 Damp Heat (steady state)

試験条件 Test Condition 85°C95%

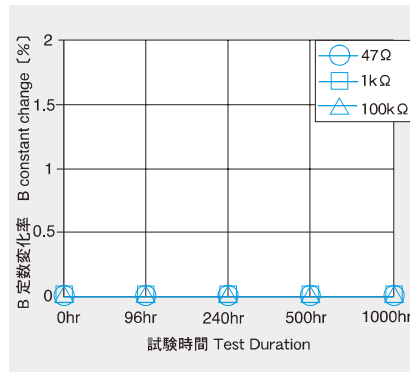
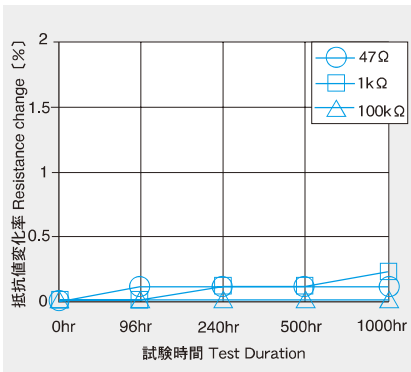

①最小受注単位数 Minimum Quantity

形式 Type	製品厚み Thickness [mm]	標準数量 Standard quantity [pcs]	
		袋づめ Bulk	紙テープ Taping
1005 (0402)	0.5 (0.020)	10000	10000
1608 (0603)	0.8 (0.031)	2000	4000

②テーピング材質 Tape material

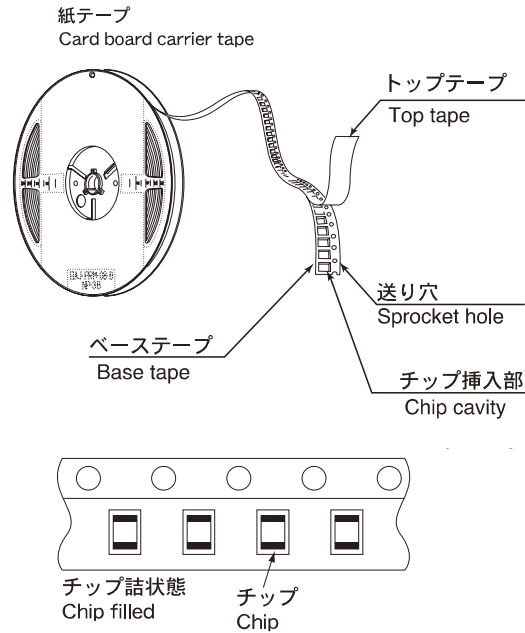

③テーピング寸法 Taping Dimensions

紙テープ (8mm幅) Paper tape (0.315inches wide)

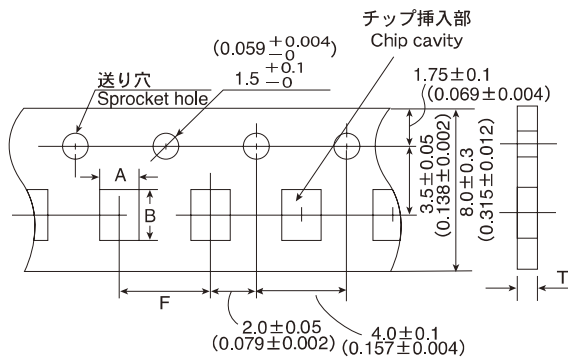

形式 Type	チップ挿入部 Chip cavity		挿入ピッチ Insertion pitch	テープ厚み Tape thickness
	A	B	F	T
1005 (0402)	0.65 ± 0.1 (0.026 ± 0.004)	1.15 ± 0.1 (0.045 ± 0.004)	2.0 ± 0.05 (0.079 ± 0.002)	0.8max (0.031max)
1608 (0603)	1.0 ± 0.2 (0.039 ± 0.008)	1.8 ± 0.2 (0.071 ± 0.008)	4.0 ± 0.1 (0.157 ± 0.004)	1.1max (0.043max)

Unit : mm (Inch)

④リーダー部・空部 Leader and Blank portion

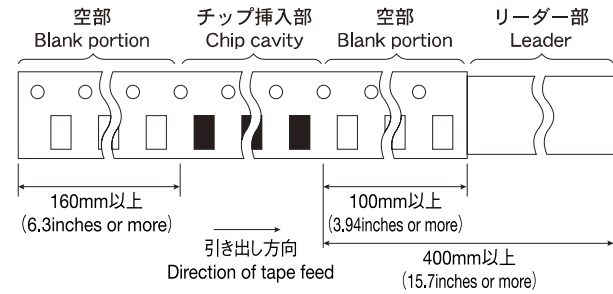

⑤リール寸法 Reel size

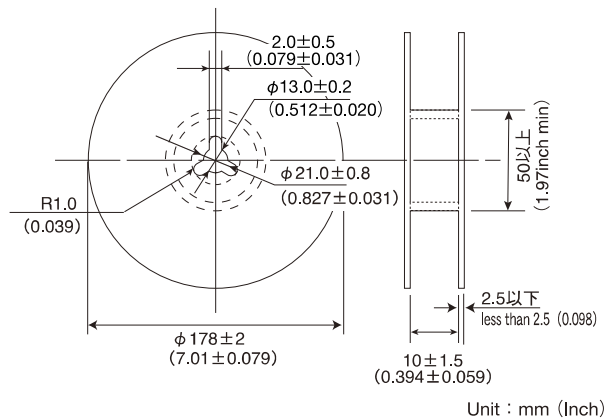

⑥トップテープ強度 Top Tape Strength

トップテープのはがし力は下図矢印方向にて0.1~0.7Nとなります。  
The top tape requires a peel-off force of 0.1~0.7N in the direction of the arrow as illustrated below.

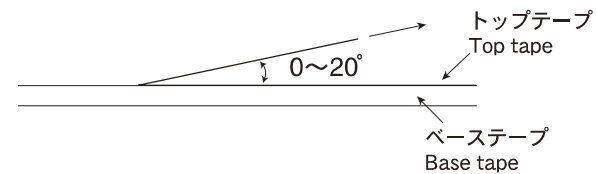

MULTILAYER CHIP NTC THERMISTORS

Item	Specified Value		Test Methods and Remarks
	1005 (0402)	1608 (0603)	
1. Operating Temperature Range	-55 to +125°C		
2. Storage Temperature Range	-55 to +125°C		
3. Rated Power	35mW	63mW	
4. Nominal Zero-Power Resistance	2.2~150kΩ ±5% ±10%	0.047~150kΩ ±5% ±10%	Ambient temperature : 25±0.2°C Measuring electric power : 0.1mW max.
5. Nominal B Constant	4100~4550K ±3%	2950~4750K ±3%	Measure the resistance at the ambient temperatures of 25±0.2°C and +85±0.2°C. $B = \frac{\ln R_{25} - \ln R_{85}}{1/T_{25} - 1/T_{85}}$ T : Absolute temperature T0 : 273.15
6. Dissipation Constant (single unit)	0.5 to 2.0mW/°C	1.0 to 2.5mW/°C	This represents the amount of electric power required to raise the temperature of the element by 1°C through self-heating under thermal equilibrium.
7. Thermal Time Constant (single unit)	Within 3 sec.	Within 5 sec.	This represents the amount of time for the temperature of the thermistor element to change by 63.2% of the difference between the initial temperature and the ambient temperature by the drastic change of power application into thermistor from non-zero-power to zero-power state.
8. Rated Ambient Temperature	25°C		This represents the maximum ambient temperature at which rated power could be applied.
9. Electric Power Derating Curve	As shown in the figure at right.		This represents the relations between the ambient temperature and the maximum permissible power.  Rated electric power ratio [%] Ambient temperature [°C] Max. Temperature
10. Resistance to Flexure of Substrate	R25 change : Within ±3% B constant change : Within ±1%	R25 change : Within ±5% B constant change : Within ±2%	Warp : 2mm Testing board : glass-epoxy-resin substrate Board thickness : 0.8mm Pressing speed : 0.5mm/sec. Duration : 30 sec.  [Unit : mm]
11. Adhesion of Terminal Electrode	R25 change : Within ±3% B constant change : Within ±1%	R25 change : Within ±5% B constant change : Within ±2%	Applied force : 5N Duration : 10sec. 

6 THERMISTORS

## MULTILAYER CHIP NTC THERMISTORS

Item	Specified Value		Test Methods and Remarks
	1005 (0402)	1608 (0603)	
12. Solderability	At least 75% of terminal electrode is covered by new solder.	At least 80% of terminal electrode is covered by new solder.	According to JIS C5102 clause 8.4. Solder temperature : 230±5°C Duration : 4±1 sec.
13. Resistance to Soldering	R25 change : Within ±3% B constant change : Within ±1%	R25 change : Within ±5% B constant change : Within ±2%	Reflow soldering : Solder temperature : 240°C Duration : 5 sec. Preheating temperature : 150°C Preheating time : 90 sec. Number of reflows : 3 times testing substrate : glass-epoxy-resin substrate
14. Thermal Shock	R25 change : Within ±3% B Constant change : Within ±1%	R25 change : Within ±5% B Constant change : Within ±3%	Conditions for 1 cycle Step1 : Minimum operating temperature +0/-3°C 30±3 min Step2 : Room temperature 2 to 3 min Step3 : Maximum operating temperature +0/-3°C 30±3 min Step4 : Room temperature 2 to 3 min Number of cycles : 5 Recovery : 2 to 3 hrs of recovery under the standard condition after the test.
15. High Temperature Life Test	R25 change : Within ±3% B Constant change : Within ±1%	R25 change : Within ±5% B Constant change : Within ±3%	Temperature : 125±2°C Duration : 1000±12 hrs Recovery : 2 hrs of recovery under the standard condition after the removal from test chamber. testing substrate : glass-epoxy-resin substrate
16. Damp Heat (steady state)	R25 change : Within ±3% B Constant change : Within ±1%	R25 change : Within ±5% B Constant change : Within ±3%	Temperature : 85±2°C Humidity : 85±5%RH Duration : 1000±12 hrs Recovery : 2 hrs of recovery under the standard condition after the removal from test chamber. testing substrate : glass-epoxy-resin substrate

Note on standard condition : "standard condition" referred to herein is defined as follows :  
5 to 35°C of temperature, 45 to 85% relative humidity and 86 to 106kPa of air pressure.

When there are questions concerning measurement results :

In order to provide correlation data, the test shall be conducted under condition of 20±2°C of temperature, 60 to 70% relative humidity and 86 to 106kPa of air pressure.

Unless otherwise specified, all the tests are conducted under the "standard condition."